

Write your name here

Surname		Other names	
Centre Number		Candidate Number	
<input type="text"/>	<input type="text"/>	<input type="text"/>	<input type="text"/>

Edexcel GCE

Physics
Advanced
Unit 4: Physics on the Move

Friday 18 June 2010 – Morning Time: 1 hour 35 minutes	Paper Reference 6PH04/01
---	------------------------------------

You must have: Ruler	Total Marks
---------------------------------------	-------------

Instructions

- Use **black** ink or ball-point pen.
- **Fill in the boxes** at the top of this page with your name, centre number and candidate number.
- Answer **all** questions.
- Answer the questions in the spaces provided – *there may be more space than you need.*

Information

- The total mark for this paper is 80.
- The marks for **each** question are shown in brackets – *use this as a guide as to how much time to spend on each question.*
- Questions labelled with an **asterisk** (*) are ones where the quality of your written communication will be assessed – *you should take particular care with your spelling, punctuation and grammar, as well as the clarity of expression, on these questions.*
- The list of data, formulae and relationships is printed at the end of this booklet.
- Candidates may use a scientific calculator.

Advice

- Read each question carefully before you start to answer it.
- Keep an eye on the time.
- Try to answer every question.
- Check your answers if you have time at the end.

Turn over ►

N36115A

©2010 Edexcel Limited.

1/1/1/1/1/1/



edexcel 
 advancing learning, changing lives

SECTION A**Answer ALL questions.**

**For questions 1–10, in Section A, select one answer from A to D and put a cross in the box ☒.
If you change your mind, put a line through the box ~~☒~~ and then
mark your new answer with a cross ☒.**

1 The number of neutrons in a nucleus of $^{197}_{79}\text{Au}$ is

- A** 79
 B 118
 C 197
 D 276

(Total for Question 1 = 1 mark)

2 Electric field strength can have the units

- A** C m^{-1}
 B N C^{-1}
 C N V^{-1}
 D V m

(Total for Question 2 = 1 mark)



3 A tennis ball is travelling horizontally with a momentum of 0.4 kg m s^{-1} just before it is hit with a tennis racket. It rebounds horizontally from the tennis racket with a momentum of -0.6 kg m s^{-1} . The graph shows the variation in the momentum of the ball during this process.

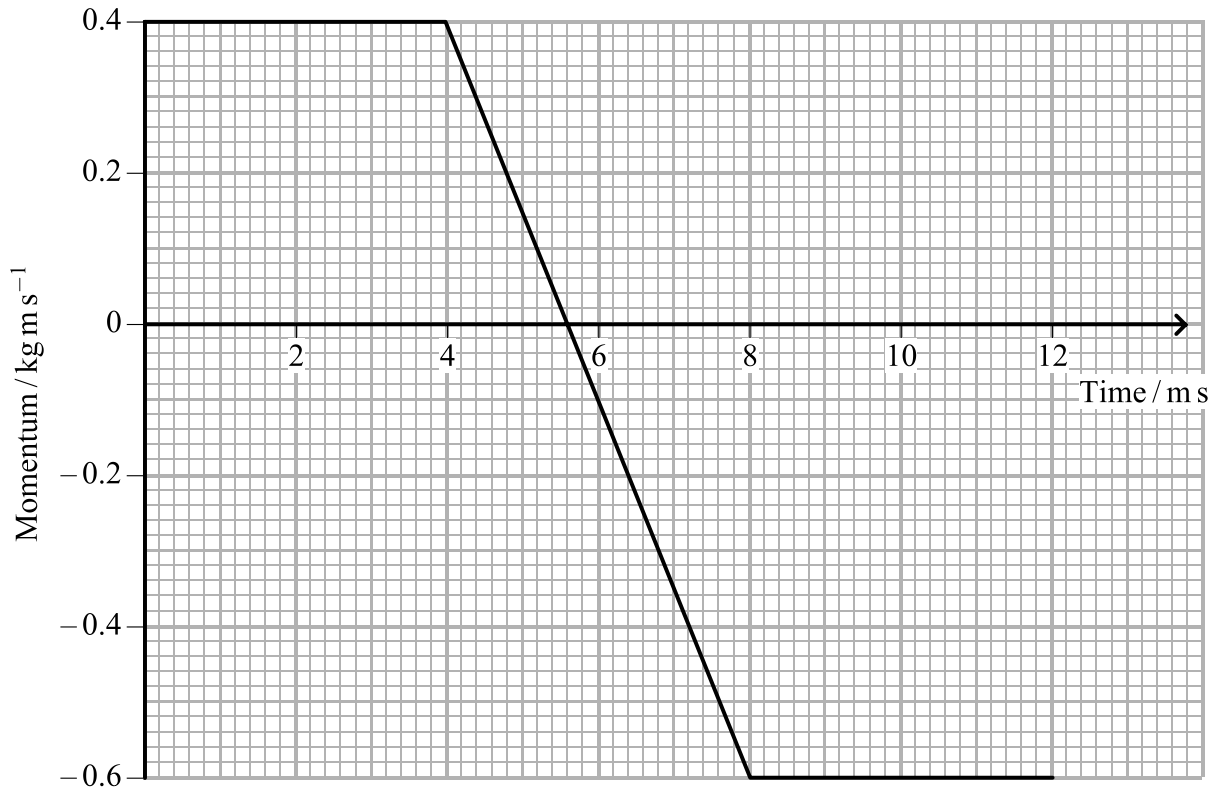

The force exerted by the tennis ball on the racket is

- A 12 N
- B 100 N
- C 250 N
- D 1000 N

(Total for Question 3 = 1 mark)



4 The derivation of the formula $E_k = \frac{p^2}{2m}$ could include the expression

- A $\frac{1}{2} mv^2 = p^2$
- B $\frac{1}{2} m^2 v^2 = p^2$
- C $m^2 v^2 = \frac{p^2}{m}$
- D $m v^2 = \frac{p^2}{m}$

(Total for Question 4 = 1 mark)

5 The distance, in m, from an electron at which the electric field strength equals $6.4 \times 10^8 \text{ J C}^{-1} \text{ m}^{-1}$ is

- A 1.7×10^{-19}
- B 6.0×10^{-19}
- C 2.2×10^{-18}
- D 1.5×10^{-9}

(Total for Question 5 = 1 mark)

6 An uncharged capacitor is connected to a battery.

Which graph shows the variation of charge with potential difference across the capacitor?

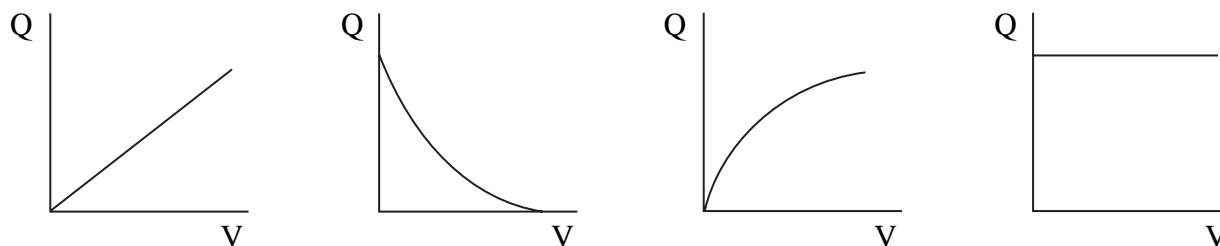

- A
- B
- C
- D

(Total for Question 6 = 1 mark)



7 Which of the following is **not** a valid conclusion from Rutherford's alpha particle scattering experiments?

- A The atom is mainly empty space.
- B The nucleus contains protons and neutrons.
- C The nucleus must be charged.
- D The nucleus must be very small compared to the atom.

(Total for Question 7 = 1 mark)

8 A 50 turn square coil, side 0.060 m, is placed in a magnetic field of flux density 0.40 T. The plane of the coil is at right angles to the direction of the magnetic field.

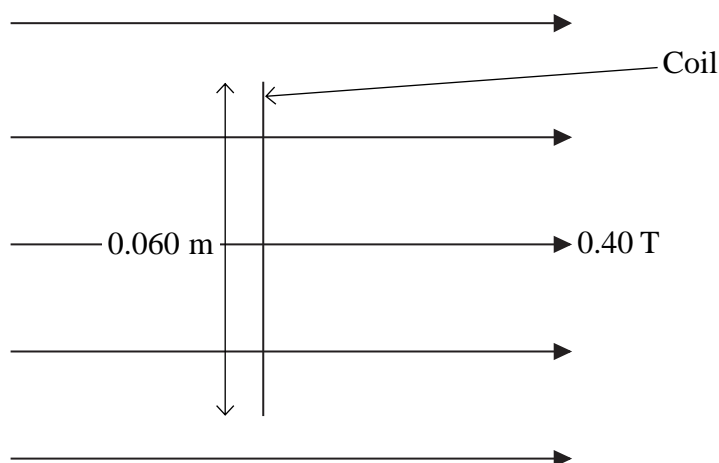

The flux linkage with the coil is

- A 0.072 Wb
- B 0.45 Wb
- C 1.2 Wb
- D 333 Wb

(Total for Question 8 = 1 mark)



9 The diagram shows the path of an electron in a bubble chamber.

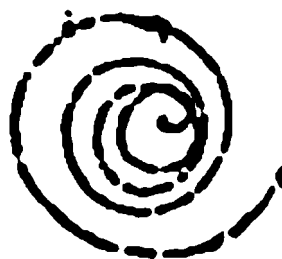

Which of the following can you deduce from the diagram?

- A The electron is moving anti-clockwise.
- B The electron is moving clockwise.
- C The magnetic field is acting out of the page.
- D The speed of the electron is increasing.

(Total for Question 9 = 1 mark)

10 Which one of the following quantities would the de Broglie equation be used to calculate?

- A The momentum of a moving particle.
- B The value of the Planck constant.
- C The wavelength of a moving electron.
- D The wavelength of a photon of light.

(Total for Question 10 = 1 mark)

TOTAL FOR SECTION A = 10 MARKS



SECTION B

Answer ALL questions in the spaces provided.

- 11 The diagram shows a horizontal wire which is at right angles to a magnetic field. The magnetic field is produced by a horseshoe magnet which is on a balance adjusted to read zero when the current in the wire is zero.

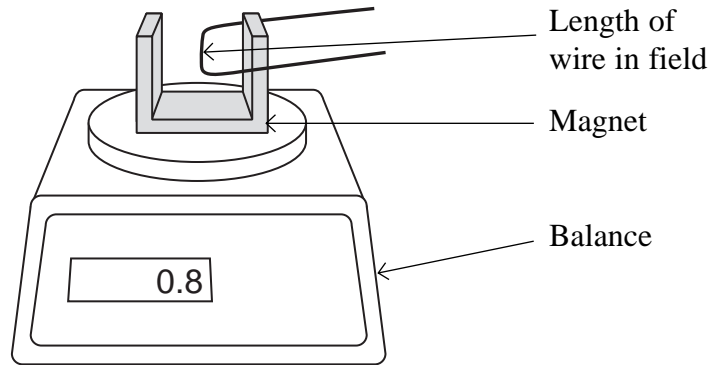

When the current is 4 A, the reading on the balance is 0.8 gram.

The length of wire in the magnetic field is 0.05 m.

Calculate the average magnetic flux density along the length of the wire.

(3)

.....

.....

.....

.....

.....

.....

.....

Magnetic flux density =

(Total for Question 11 = 3 marks)



*12 Faraday's and Lenz's laws are summarised in the list of formulae as

$$\varepsilon = -\frac{d(N\phi)}{dt}$$

(a) State the meaning of the term $N\phi$.

(2)

.....

.....

(b) Explain the significance of the minus sign.

(3)

.....

.....

.....

.....

.....

.....

.....

.....

(Total for Question 12 = 5 marks)



13 Astronauts can be weakened by the long-term effects of microgravity. To keep in shape it has been suggested that they can do some exercise using a Space Cycle: a horizontal beam from which an exercise bike and a cage are suspended. One astronaut sits on the exercise bike and pedals, which causes the whole Space Cycle to rotate around a pole. Another astronaut standing in the cage experiences artificial gravity. When rotated at 20 revolutions per minute, this is of similar strength to the gravitational field on Earth.

Space Cycle

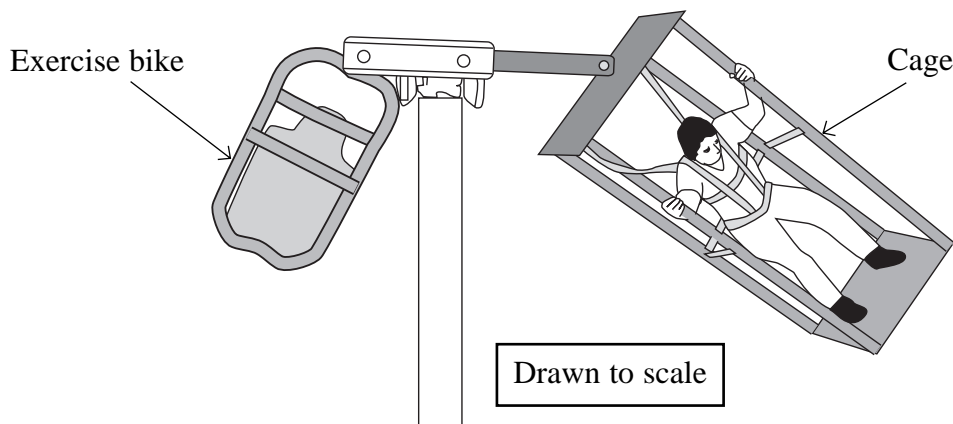

(a) Calculate the angular velocity, in rad s^{-1} , corresponding to 20 revolutions per minute.

(2)

.....

.....

.....

.....

Angular velocity =

(b) Use the diagram to estimate the radius of the path followed by the cage's platform and hence calculate the platform's acceleration.

(3)

.....

.....

.....

.....

.....

.....

Acceleration =

(Total for Question 13 = 5 marks)



***14** How tiny bacteria move is of interest in nanotechnology. Mycobacteria move by ejecting slime from nozzles in their bodies.

Explain the physics principles behind this form of propulsion.

(4)

.....

.....

.....

.....

.....

.....

.....

.....

.....

.....

.....

.....

.....

.....

.....

.....

.....

.....

.....

.....

.....

.....

.....

(Total for Question 14 = 4 marks)



15 Time-of-flight mass spectroscopy uses the arrangement below to measure the mass of molecules. A laser pulse knocks an electron out of a molecule in a sample leaving it as a positively charged ion.

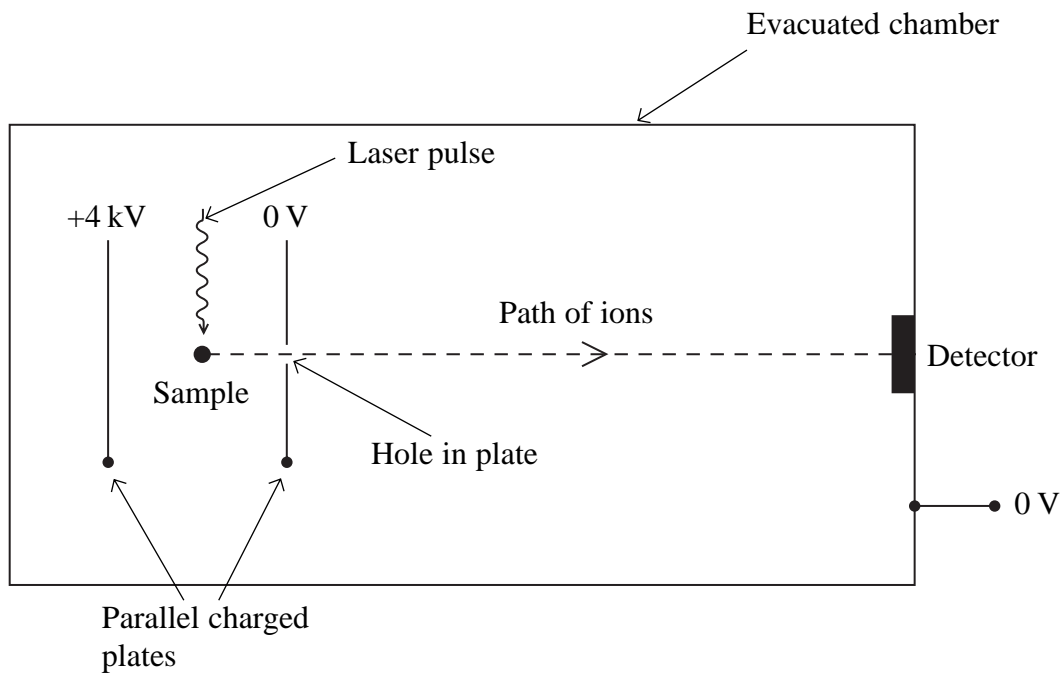

(a) Add to the diagram to show the electric field lines between the two plates. (3)

(b) The sample is midway between the charged plates. Show that the speed, v , of an ion as it reaches the hole in the plate is given by

$$v = \sqrt{\frac{6.4 \times 10^{-16} \text{ joule}}{m}}$$

where m is the mass of the molecule in kg. (3)

.....

.....

.....

.....

.....

.....

.....



(c) The distance between the hole in the plate and the detector is 1.5 m. The time taken for a molecule to cover this distance is 23 μ s.

Calculate the mass of this molecule.

(3)

.....

.....

.....

.....

.....

.....

Mass =

(d) There is some uncertainty in the time a molecule with a particular mass will take to cover this distance.

Suggest **two** reasons for this.

(2)

1

.....

.....

.....

2

.....

.....

.....

(Total for Question 15 = 11 marks)



16 Figure 1 shows the output from the terminals of a power supply labelled d.c. (direct current).

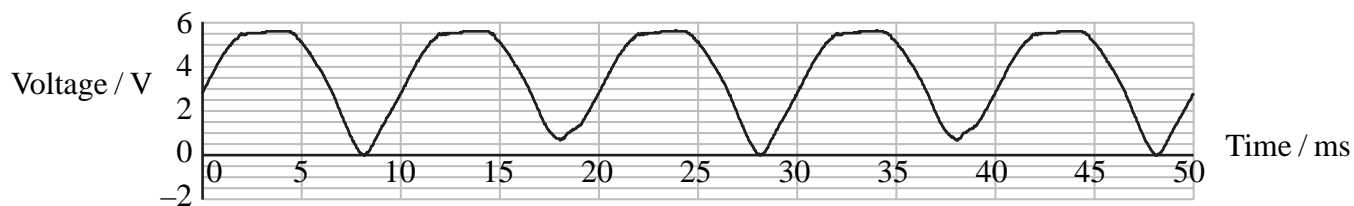

Figure 1

(a) An alternating current power supply provides a current that keeps switching direction.

Explain why the output shown in Figure 1 is consistent with the d.c. label.

(2)

.....

.....

.....

.....

(b) A teacher suggests that certain electronic circuits require a constant voltage supply to operate correctly.

(i) A student places a capacitor across the terminals of this power supply. Suggest how this produces a constant voltage.

(2)

.....

.....

.....

.....



(ii) She uses a $10 \mu\text{F}$ capacitor. Calculate the maximum energy stored in the capacitor.

(3)

.....

.....

.....

.....

.....

.....

Maximum Energy =

(c) She now adds an electronic circuit to the power supply plus capacitor. Figure 2 shows the supply to the electronic circuit. This is shown in Figure 2.

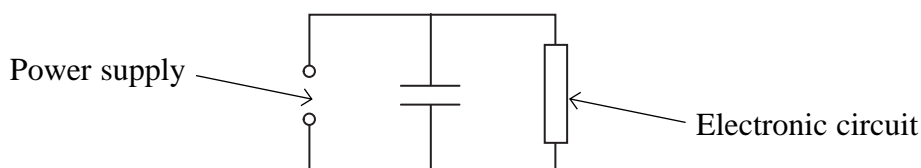

Figure 2

The variation in potential difference is shown by the graph in Figure 3.

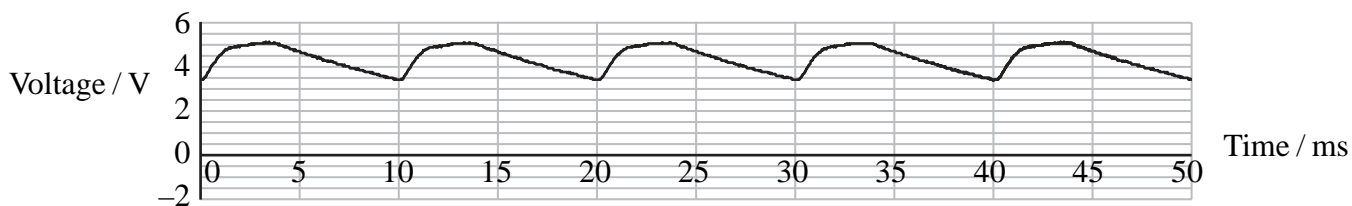

Figure 3

(i) Explain the shape of this graph.

(3)

.....

.....

.....

.....

.....

.....



(ii) Take readings from the graph to show that the resistance of the electronic circuit is in the range $1000\ \Omega$ to $2000\ \Omega$.

(3)

.....

.....

.....

.....

.....

.....

(iii) Figure 3 shows that the voltage supplied to the electronic circuit still varies. How could the student make it more constant?

(1)

.....

.....

(Total for Question 16 = 14 marks)



17 A low-energy particle collides elastically with a stationary particle of the same mass. The particle enters from the left of the photograph.

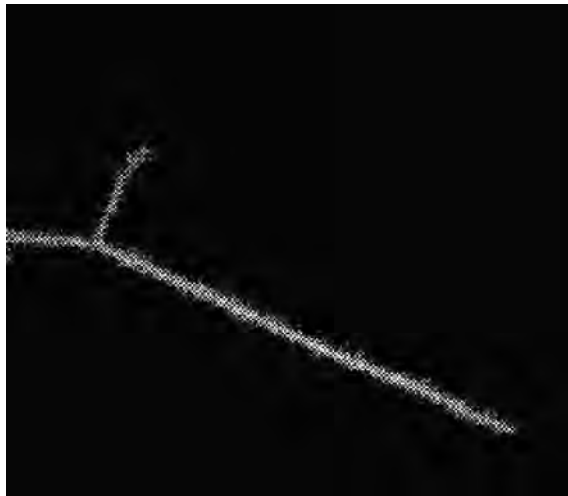

(a) State what is meant by collides *elastically*.

(1)

.....

.....

(b) Sketch a labelled vector diagram to show how the momentum of the initial moving particle relates to the momenta of the two particles after the collision.

(2)

.....

.....

.....

.....

(c) Use your answers to (a) and (b) to confirm that the angle between the subsequent paths of both particles must be 90° .

(2)

.....

.....

.....

.....



(d) (i) Explain the process by which a proton is given energy in a particle accelerator. (3)

.....

.....

.....

.....

.....

.....

The diagram shows a collision between a high-energy proton (track from the left) and a stationary proton in a particle accelerator experiment.

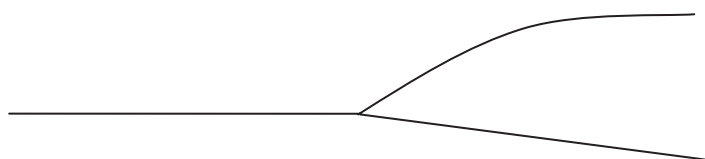

(ii) Explain why the angle between the two paths is not 90°. (2)

.....

.....

.....

.....

(e) Deduce the direction of the magnetic field in this particle accelerator experiment. Circle the correct direction from those given below. (1)

left to right across the paper out of the plane of the paper into the plane of the paper

(Total for Question 17 = 11 marks)



***18** In 1961 Murray Gell-Mann predicted the existence of a new particle called an omega (Ω) minus. It was subsequently discovered in 1964.

At this time the quark model consisted of three particles, the properties of which are given in the table.

Quark	Charge	Predicted mass in MeV/c^2
Up (u)	$+\frac{2}{3}$	4
Down (d)	$-\frac{1}{3}$	4
Strange (s)	$-\frac{1}{3}$	80

(a) Explain what a charge of $+\frac{2}{3}$ means.

(1)

.....

.....

(b) State the predicted mass of, and the charge on a \bar{s} .

(2)

.....

.....

(c) Convert $4 \text{ MeV}/c^2$ to kg.

(3)

.....

.....

.....

.....

.....

.....

.....

Mass = kg



(d) The event which led to the discovery of the omega minus particle can be summarised as follows. A negative kaon collided with a stationary proton and produced a positive kaon, a neutral kaon and the omega minus.

(i) Kaons K consist of combinations of either an up or down quark plus a strange quark. The omega minus consists of three strange quarks.

Complete the following table by ticking the appropriate boxes.

(2)

	Meson	Baryon	Nucleon	Lepton
Negative kaon				
Omega minus				

(ii) Write an equation using standard particle symbols to summarise this event.

(2)

.....

.....

.....

.....

(iii) The negative kaon consists of $\bar{u}s$. Deduce the quark structure of the other two kaons involved in this event.

(2)

.....

.....

.....

.....



(iv) The total mass of the three particles created after this event is larger than the total mass of the two particles before. Discuss the quantities that must be conserved in interactions between particles and use an appropriate conservation law to explain this increase in mass.

(5)

.....

.....

.....

.....

.....

.....

.....

.....

.....

.....

.....

.....

.....

.....

.....

.....

.....

.....

.....

.....

.....

.....

.....

(Total for Question 18 = 17 marks)

TOTAL FOR SECTION B = 70 MARKS

TOTAL FOR PAPER = 80 MARKS



List of data, formulae and relationships

Acceleration of free fall	$g = 9.81 \text{ m s}^{-2}$	(close to Earth's surface)
Boltzmann constant	$k = 1.38 \times 10^{-23} \text{ J K}^{-1}$	
Coulomb's law constant	$k = 1/4\pi\epsilon_0$ $= 8.99 \times 10^9 \text{ N m}^2 \text{ C}^{-2}$	
Electron charge	$e = -1.60 \times 10^{-19} \text{ C}$	
Electron mass	$m_e = 9.11 \times 10^{-31} \text{ kg}$	
Electronvolt	$1 \text{ eV} = 1.60 \times 10^{-19} \text{ J}$	
Gravitational constant	$G = 6.67 \times 10^{-11} \text{ N m}^{-2} \text{ kg}^{-2}$	
Gravitational field strength	$g = 9.81 \text{ N kg}^{-1}$	(close to Earth's surface)
Permittivity of free space	$\epsilon_0 = 8.85 \times 10^{-12} \text{ F m}^{-1}$	
Planck constant	$h = 6.63 \times 10^{-34} \text{ J s}$	
Proton mass	$m_p = 1.67 \times 10^{-27} \text{ kg}$	
Speed of light in a vacuum	$c = 3.00 \times 10^8 \text{ m s}^{-1}$	
Stefan-Boltzmann constant	$\sigma = 5.67 \times 10^{-8} \text{ W m}^{-2} \text{ K}^{-4}$	
Unified atomic mass unit	$u = 1.66 \times 10^{-27} \text{ kg}$	

Unit 1*Mechanics*

Kinematic equations of motion	$v = u + at$ $s = ut + \frac{1}{2}at^2$ $v^2 = u^2 + 2as$
Forces	$\Sigma F = ma$ $g = F/m$ $W = mg$
Work and energy	$\Delta W = F\Delta s$ $E_k = \frac{1}{2}mv^2$ $\Delta E_{\text{grav}} = mg\Delta h$

Materials

Stokes' law	$F = 6\pi\eta rv$
Hooke's law	$F = k\Delta x$
Density	$\rho = m/V$
Pressure	$p = F/A$
Young's modulus	$E = \sigma/\epsilon$ where Stress $\sigma = F/A$ Strain $\epsilon = \Delta x/x$
Elastic strain energy	$E_{\text{el}} = \frac{1}{2}F\Delta x$



Unit 2*Waves*

Wave speed $v = f\lambda$

Refractive index ${}_1\mu_2 = \sin i / \sin r = v_1 / v_2$

Electricity

Potential difference $V = W/Q$

Resistance $R = V/I$

Electrical power, energy and efficiency
 $P = VI$
 $P = I^2R$
 $P = V^2/R$
 $W = VIt$

$$\% \text{ efficiency} = \frac{\text{useful energy output}}{\text{energy input}} \times 100$$

$$\% \text{ efficiency} = \frac{\text{useful power output}}{\text{power input}} \times 100$$

Resistivity $R = \rho l/A$

Current
 $I = \Delta Q / \Delta t$
 $I = nqvA$

Resistors in series $R = R_1 + R_2 + R_3$

Resistors in parallel
 $\frac{1}{R} = \frac{1}{R_1} + \frac{1}{R_2} + \frac{1}{R_3}$

Quantum physics

Photon model $E = hf$

Einstein's photoelectric equation
 $hf = \phi + \frac{1}{2}mv_{\max}^2$



Unit 4*Mechanics*

Momentum	$p = mv$
Kinetic energy of a non-relativistic particle	$E_k = p^2/2m$
Motion in a circle	$v = \omega r$ $T = 2\pi/\omega$ $F = ma = mv^2/r$ $a = v^2/r$ $a = r\omega^2$

Fields

Coulomb's law	$F = kQ_1Q_2/r^2$ where $k = 1/4\pi\epsilon_0$
Electric field	$E = F/Q$ $E = kQ/r^2$ $E = V/d$
Capacitance	$C = Q/V$
Energy stored in capacitor	$W = \frac{1}{2}QV$
Capacitor discharge	$Q = Q_0e^{-t/RC}$
In a magnetic field	$F = BIl \sin \theta$ $F = Bqv \sin \theta$ $r = p/BQ$
Faraday's and Lenz's Laws	$\epsilon = -d(N\phi)/dt$

Particle physics

Mass-energy	$\Delta E = c^2 \Delta m$
de Broglie wavelength	$\lambda = h/p$

