

Surname	Centre Number	Candidate Number
Other Names		2



GCE A level

1094/01

CHEMISTRY – CH4

P.M. MONDAY, 14 January 2013

1³/₄ hours

ADDITIONAL MATERIALS

In addition to this examination paper, you will need:

- a calculator;
- an 8 page answer book;
- a **Data Sheet** which contains a **Periodic Table** supplied by WJEC.

Refer to it for any **relative atomic masses** you require.

INSTRUCTIONS TO CANDIDATES

Use black ink or black ball-point pen.

Write your name, centre number and candidate number in the spaces at the top of this page.

Section A Answer **all** questions in the spaces provided.

Section B Answer **both** questions in **Section B** in a separate answer book which should then be placed inside this question-and-answer book.

Candidates are advised to allocate their time appropriately between **Section A (40 marks)** and **Section B (40 marks)**.

INFORMATION FOR CANDIDATES

The number of marks is given in brackets at the end of each question or part-question.

The maximum mark for this paper is 80.

Your answers must be relevant and must make full use of the information given to be awarded full marks for a question.

The *QWC* label alongside particular part-questions indicates those where the Quality of Written Communication is assessed.

FOR EXAMINER'S USE ONLY		
Section	Question	Mark
A	1	
	2	
	3	
B	4	
	5	
TOTAL MARK		

SECTION A

Answer all questions in the spaces provided.

Examiner
only

1. (a) From the information given, draw the displayed formula of each compound.
In parts (i)-(iii) the compounds consist of molecules that have **three** carbon atoms.
In part (iv) the compound has **four** carbon atoms.
- (i) A compound that is oxidised to a ketone [1]
- (ii) A neutral sweet-smelling compound [1]
- (iii) An α -amino acid [1]
- (iv) A hydrocarbon that exhibits E–Z isomerism [1]

- (b) The active compound in Ventolin[®] inhalers used by asthma sufferers is salbutamol, which shows optical isomerism.

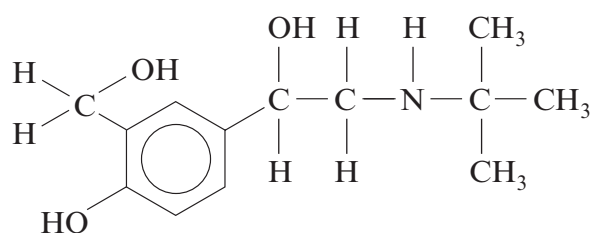

salbutamol

- (i) Indicate a chiral centre in this molecule by labelling it with an asterisk (*). [1]
- (ii) State how the optical isomers of salbutamol could be distinguished from each other. [1]
-
-
- (iii) Suggest a reason why only one optical isomer of salbutamol is used as a pharmaceutical. [1]
-
- (iv) Draw the displayed formula of the likely organic product formed when salbutamol is refluxed with acidified $K_2Cr_2O_7$. [2]

(c) (i) Arrange the following molecules in order of **increasing** acidity. [1]

ethanoic acid *ethanol* *ethylamine* *phenol*

least
acidic

most
acidic

(ii) Explain the difference in acid-base properties of ethylamine and phenol. [4]

.....

.....

.....

.....

.....

.....

Total [14]

Examiner
only

BLANK PAGE

1094
010005

2. (a) 2,4-Dinitrophenylhydrazine reagent (2,4-DNP), Tollens' reagent and iodine in sodium hydroxide solution can all be used in the laboratory to identify unknown compounds. Complete the table below by giving any observations made (or writing 'no reaction' as appropriate) when these reagents are added to the compounds listed. [4]

	butan-2-ol	ethanal	ethanol	propanone
2,4-DNP	no reaction			
Tollens' reagent			no reaction	
I ₂ /NaOH				

- (b) Under certain conditions ethanol can be formed from ethene and water. A possible mechanism for this reaction is shown below.



- (i) Classify this type of mechanism. [1]
.....
- (ii) State the name given to species such as the intermediate ion CH_3CH_2^+ . [1]
.....
- (iii) Give another reaction of ethene that follows this type of mechanism. [1]
.....
- (iv) Give a reason why the main product of the reaction between propene and water under similar conditions is propan-2-ol. [1]
.....
.....

(c) Propanone can react with hydrogen cyanide.

(i) Classify the type of reaction taking place when propanone reacts in this way. [1]

.....

(ii) Draw the mechanism for this reaction. [3]

Total [12]

Examiner
only

1094
010007

3. Read the passage below and then answer the questions in the spaces provided.

Tastes in food

The sensation of taste can be categorized into five basic tastes: sweet, bitter, sour, salty and umami. Humans receive tastes through sensory organs called taste buds concentrated on the top of the tongue. Pungency also helps us to describe the tastes that we encounter in food. Some of these tastes are described below.

5 Sweetness

One theory in the 1960s proposed that to be sweet, a compound must contain a hydrogen bond donor (AH) and a hydrogen bond acceptor (B).

Human taste buds are much more sensitive to synthetic sweeteners than to naturally-occurring sugars. For example, aspartame is 200 times sweeter than sucrose.

10

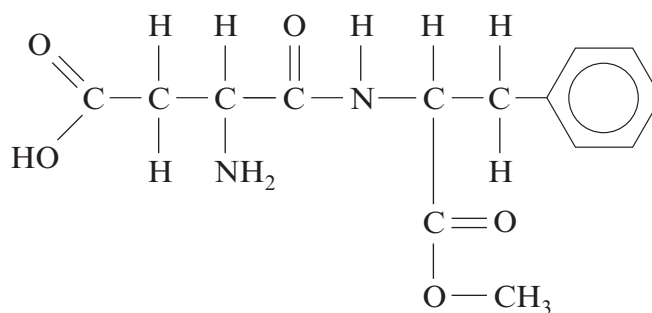

aspartame

Umami

Umami is a Japanese word meaning ‘good flavour’ or ‘good taste’ and is described as a savoury or meaty taste. Monosodium glutamate (MSG), the monosodium salt of glutamic acid, was developed as a food additive in 1908 by a Japanese scientist and produces a strong umami taste.

15

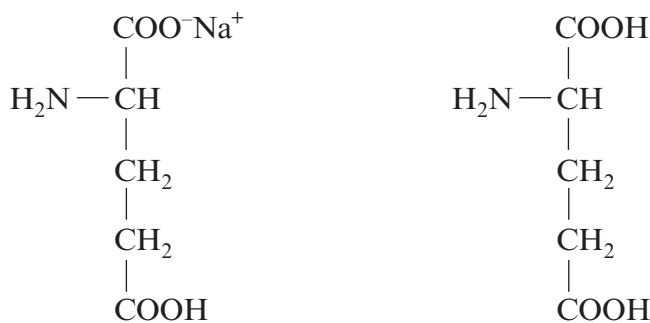

MSG

glutamic acid

Other foods that have always been popular as flavourings are now known to be rich in umami substances. These include seaweeds, fish, mushrooms and tomatoes.

Like other basic tastes, MSG improves pleasantness only in the right concentration. An excess of MSG quickly ruins the taste of a dish e.g. in clear soup the ‘pleasantness score’ rapidly falls with 1 g or more of MSG per 100 cm³.

20

Pungency

25

One group of compounds that produce a sensation of pungency or heat contain an aromatic ring system carrying two oxygen atoms. This seems to be the key structure responsible for their interaction with the taste buds. Two examples are shown below.

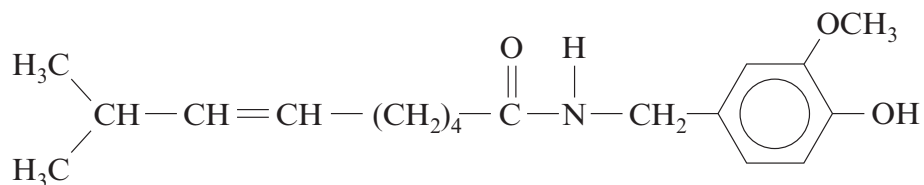

capsaicin (chilli peppers)

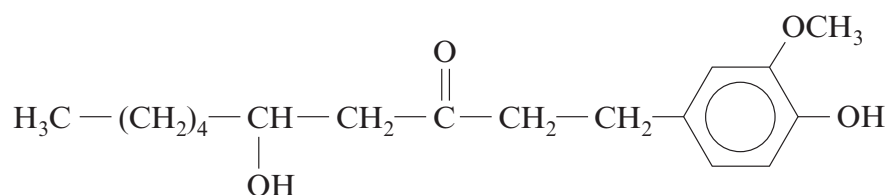

gingerol (ginger)

– End of passage –

- (a) Describe what is meant by hydrogen bonding, using an example of your choice. [3]
QWC [1]

.....

.....

.....

.....

.....

.....

.....

- (b) Aspartame (*line 10*) is a methyl ester of a dipeptide formed from two α -amino acids. The structure of one of the acids is as shown below.

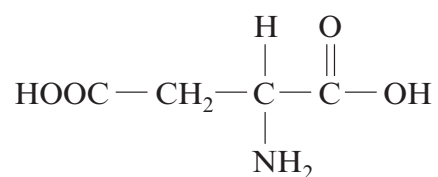

Draw the structure of the other α -amino acid.

[1]

- (c) Glutamic acid (*line 16*) is amphoteric. Explain the meaning of the term *amphoteric* and why glutamic acid exhibits amphoteric behaviour.

[2]

.....

.....

.....

- (d) Draw the **skeletal** formula of glutamic acid.

[1]

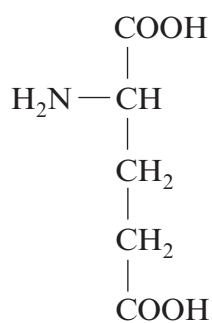

glutamic acid

- (e) Calculate the minimum concentration of MSG, in mol dm^{-3} , which if added to clear soup makes its 'pleasantness score' rapidly fall (*lines 20-21*). [2]

Examiner
only

Minimum concentration = mol dm^{-3}

- (f) Giving the reagent(s) and an observation, state a chemical test that gives a positive result with both capsaicin and gingerol (*lines 26-27*). [2]

Reagent(s)

Observation

- (g) Giving the reagent(s) and an observation, state a chemical test that gives a positive result with gingerol but **not** with capsaicin. [2]

Reagent(s)

Observation

Total [14]

Total Section A [40]

SECTION B

Answer **both** questions in the separate answer book provided.

4. (a) Today there are thousands of different polymers and they are used in a wide range of applications.

Describe the formation of **one** synthetic polymer and **one** natural polymer, both made by condensation polymerisation.

Your answer should include

- the names or structures of the starting materials required for both polymers,
- a structure which shows the repeating unit for the synthetic polymer,
- a structure which shows the relevant linkage in the natural polymer.

[5]
QWC [1]

- (b) **F** and **G** are two organohalogen compounds.

(chloromethyl) benzene

F

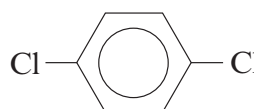

G

Compound **F** is used in the manufacture of plasticizers and perfumes and behaves as a chloroalkane. Compound **G** is used as a pesticide and as a deodorant.

- (i) Draw the displayed formula of compound **F**. [1]
- (ii) Name compound **G**. [1]
- (iii) State the reagent(s) and condition(s) needed to substitute a chlorine atom into a benzene ring. [2]
- (iv) Describe how you could use a chemical test to distinguish between compounds **F** and **G**. Give the expected result for **each** compound and an explanation for any difference in their behaviour. [6]

QWC [1]

- (c) Benzenediazonium chloride can be prepared as follows. Phenylamine is dissolved in excess hydrochloric acid and the solution cooled to 5°C. Aqueous sodium nitrate(III), NaNO₂, is added gradually until in excess, keeping the temperature at approximately 5°C.

- (i) State why the temperature is kept under 10°C. [1]
- (ii) Give the displayed formula of the compound that forms when benzenediazonium chloride reacts with naphthalene-2-ol in alkaline conditions. [1]
- (iii) State what is meant by the term *chromophore*. [1]

Total [20]

5. (a) Study the reaction scheme shown below and the other information about compounds **A-D** that follows.

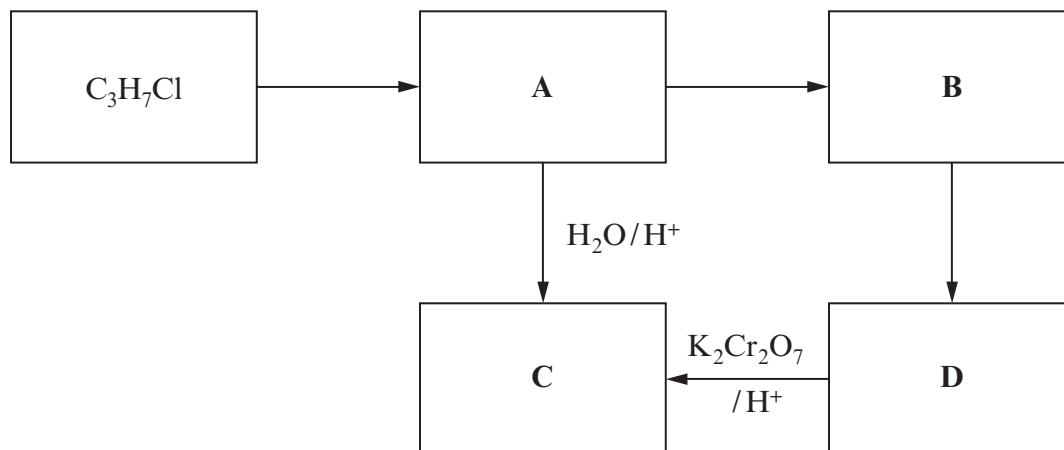

Compound **A** contains a straight carbon chain and contains only carbon, hydrogen and nitrogen.

Compound **B** is basic and reacts with hydrochloric acid in a 1:1 molar ratio.

0.395 g of compound **B** in aqueous solution requires 54.00 cm³ of hydrochloric acid solution of concentration 0.100 mol dm⁻³ for complete neutralisation.

Compound **C** reacts with sodium carbonate giving off carbon dioxide.

- (i) Calculate the relative molecular mass of compound **B**. Show your working. [2]
 - (ii) Identify the structures of compounds **A-D**, giving your full reasoning. [8]
- (b) C₃H₇Cl exists as two isomers. Sketch the **low** resolution NMR spectra of both isomers giving the approximate chemical shift (ppm) and the relative area of each peak. [4]

QUESTION 5 CONTINUES ON PAGES 14 AND 15

(c) Phenol can be made by the following three-step synthesis.

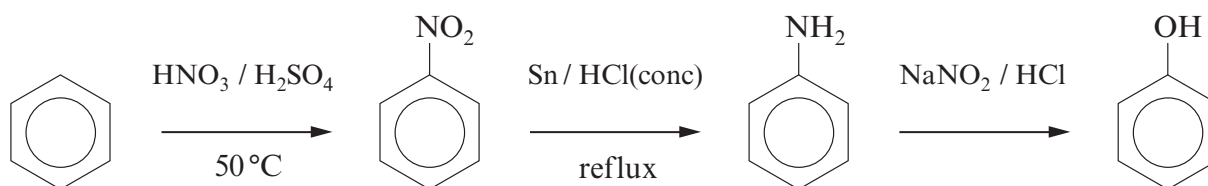

However, the industrial method of making phenol uses a different route as shown below.

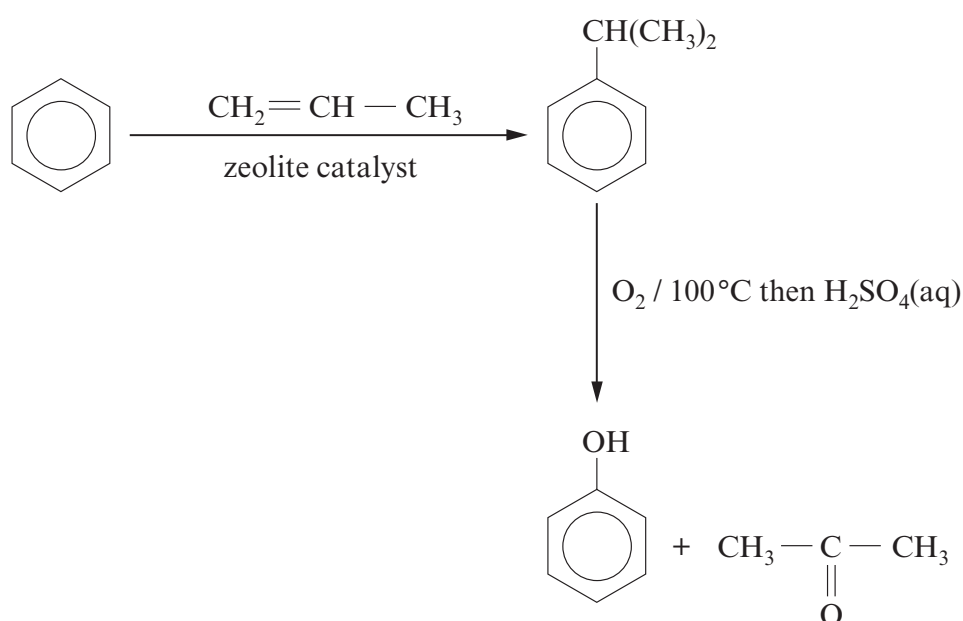

- (i) Give **two** possible advantages of the industrial route. [2]
- (ii) Until 1995 solid phosphoric acid was used as the catalyst for the first stage of the industrial route. Suggest a reason, apart from an increased reaction rate, why this was changed to a zeolite catalyst. [1]

(d) Phenol can be converted into aspirin.

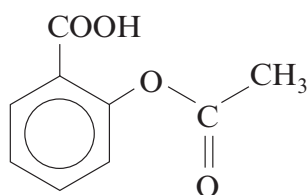

aspirin

When 58.75 g of phenol was reacted with the appropriate chemicals, the yield of aspirin was 65%. Calculate the mass of aspirin produced in this process. [3]

Total [20]

Section B Total [40]

END OF PAPER



GCE A level

1094/01-A

**CHEMISTRY – DATA SHEET
FOR USE WITH CH4**

P.M. MONDAY, 14 January 2013

Infrared Spectroscopy characteristic absorption values

Bond	Wavenumber / cm ⁻¹
C—Br	500 to 600
C—Cl	650 to 800
C—O	1000 to 1300
C=C	1620 to 1670
C=O	1650 to 1750
C≡N	2100 to 2250
C—H	2800 to 3100
O—H	2500 to 3550
N—H	3300 to 3500

Nuclear Magnetic Resonance Spectroscopy

Candidates are reminded that the splitting of any resonance into **n** components indicates the presence of **n-1** hydrogen atoms on the **adjacent** carbon, oxygen or nitrogen atoms.

Typical proton chemical shift values (δ) relative to TMS = 0

Type of proton	Chemical shift / ppm
—CH ₃	0.1 to 2.0
R—CH ₃	0.9
R—CH ₂ —R	1.3
CH ₃ —C≡N	2.0
$\begin{array}{c} \text{O} \\ \parallel \\ \text{CH}_3-\text{C} \\ \diagdown \end{array}$	2.0 to 2.5
$\begin{array}{c} \text{O} \\ \parallel \\ -\text{CH}_2-\text{C} \\ \diagdown \end{array}$	2.0 to 3.0
R—CH ₂ Cl, R—CHCl—R	3.0 to 4.3
R—OH	4.5 *
$\begin{array}{c} \text{O} \\ \parallel \\ \text{R}-\text{C} \\ \diagdown \\ \text{H} \end{array}$	9.8 *
$\begin{array}{c} \text{O} \\ \parallel \\ \text{R}-\text{C} \\ \diagdown \\ \text{OH} \end{array}$	11.0 *

*variable figure dependent on concentration and solvent

THE PERIODIC TABLE

Group 1 2 3 4 5 6 7 0

Period 1 2 3 4 5 6 7

4.00 He Helium 2

p Block

10.8 B Boron 5	12.0 C Carbon 6	14.0 N Nitrogen 7	16.0 O Oxygen 8	19.0 F Fluorine 9	20.2 Ne Neon 10
27.0 Al Aluminium 13	28.1 Si Silicon 14	31.0 P Phosphorus 15	32.1 S Sulfur 16	35.5 Cl Chlorine 17	40.0 Ar Argon 18
69.7 Ga Gallium 31	72.6 Ge Germanium 32	74.9 As Arsenic 33	79.0 Se Selenium 34	79.9 Br Bromine 35	83.8 Kr Krypton 36
115 In Indium 49	119 Sn Tin 50	122 Sb Antimony 51	128 Te Tellurium 52	127 I Iodine 53	131 Xe Xenon 54
204 Tl Thallium 81	207 Pb Lead 82	209 Bi Bismuth 83	(210) Po Polonium 84	(210) At Astatine 85	(222) Rn Radon 86

Key	
A_r	relative atomic mass
Symbol	Name
Z	atomic number

d Block

65.4 Zn Zinc 30	63.5 Cu Copper 29	58.7 Ni Nickel 28	58.9 Co Cobalt 27	55.8 Fe Iron 26	54.9 Mn Manganese 25	52.0 Cr Chromium 24	50.9 V Vanadium 23	47.9 Ti Titanium 22	45.0 Sc Scandium 21
112 Cd Cadmium 48	108 Ag Silver 47	106 Pd Palladium 46	103 Rh Rhodium 45	101 Ru Ruthenium 44	98.9 Tc Technetium 43	95.9 Mo Molybdenum 42	92.9 Nb Niobium 41	91.2 Zr Zirconium 40	88.9 Y Yttrium 39
201 Hg Mercury 80	197 Au Gold 79	195 Pt Platinum 78	192 Ir Iridium 77	190 Os Osmium 76	186 Re Rhenium 75	184 W Tungsten 74	181 Ta Tantalum 73	179 Hf Hafnium 72	139 La Lanthanum 57
(227) Fr Francium 87	(226) Ra Radium 88	(227) Ac Actinium 89							

f Block

175 Lu Lutetium 71	173 Yb Ytterbium 70	169 Tm Thulium 69	167 Er Erbium 68	165 Ho Holmium 67	163 Dy Dysprosium 66	159 Tb Terbium 65	157 Gd Gadolinium 64	(153) Eu Europium 63	150 Sm Samarium 62	(147) Pm Promethium 61	144 Nd Neodymium 60	141 Pr Praseodymium 59	140 Ce Cerium 58
(257) Lr Lawrencium 103	(254) No Nobelium 102	(256) Md Mendelevium 101	(253) Fm Fermium 100	(254) Es Einsteinium 99	(251) Cf Californium 98	(245) Bk Berkelium 97	(247) Cm Curium 96	(243) Am Americium 95	(242) Pu Plutonium 94	(237) Np Neptunium 93	238 U Uranium 92	(231) Pa Protactinium 91	232 Th Thorium 90

► Lanthanoid elements

►► Actinoid elements