

# Mark Scheme (SAM)

## Pearson Edexcel International Advanced Subsidiary in Chemistry

### Unit 2: Application of Core Principles of Chemistry

All the material in this publication is copyright  
© Pearson Education Ltd 2013

## General marking guidance

- All candidates must receive the same treatment. Examiners must mark the first candidate in exactly the same way as they mark the last.
- Mark schemes should be applied positively. Candidates must be rewarded for what they have shown they can do rather than penalised for omissions.
- Examiners should mark according to the mark scheme not according to their perception of where the grade boundaries may lie.
- There is no ceiling on achievement. All marks on the mark scheme should be used appropriately.
- All the marks on the mark scheme are designed to be awarded. Examiners should always award full marks if deserved, i.e. if the answer matches the mark scheme. Examiners should also be prepared to award zero marks if the candidate's response is not worthy of credit according to the mark scheme.
- Where some judgement is required, mark schemes will provide the principles by which marks will be awarded and exemplification may be limited.
- When examiners are in doubt regarding the application of the mark scheme to a candidate's response, the team leader must be consulted.
- Crossed-out work should be marked UNLESS the candidate has replaced it with an alternative response.
- Mark schemes will indicate within the table where, and which strands of Quality of Written Communication, are being assessed. The strands are as follows:
  - i. ensure that text is legible and that spelling, punctuation and grammar are accurate so that meaning is clear
  - ii. select and use a form and style of writing appropriate to purpose and to complex subject matter
  - iii. organise information clearly and coherently, using specialist vocabulary when appropriate.

## Using the Mark Scheme

Examiners should NOT give credit for incorrect or inadequate answers, but allow candidates to be rewarded for answers showing correct application of principles and knowledge. Examiners should therefore read carefully and consider every response: even if it is not what is expected, it may still be creditworthy.

The mark scheme gives examiners:

- an idea of the types of response expected
- how individual marks are to be awarded
- the total mark for each question
- examples of responses that should NOT receive credit.

|             |   |
|-------------|---|
| /           | Means that the responses are alternatives and either answer should receive full credit.   |
| ()          | Means that a phrase/word is not essential for the award of the mark, but helps the examiner to get the sense of the expected answer.  |
| <b>Bold</b> | Phrases/words in <b>bold</b> indicate that the meaning of the phrase or the actual word is <b>essential</b> to the answer.  |
| ecf/TE/cq   | (error carried forward)(transfer error)(consequential) means that a wrong answer given in an earlier part of a question is used correctly in answer to a later part of the same question. |

Candidates must make their meaning clear to the examiner to gain the mark. Do not give credit for correct words/phrases which are put together in a meaningless manner. Answers must be in the correct context.

## Quality of Written Communication

Questions that involve the writing of continuous prose require candidates to:

- write legibly, with accurate use of spelling, grammar and punctuation in order to make the meaning clear
- select and use a form and style of writing appropriate to purpose and to complex subject matter
- organise information clearly and coherently, using specialist vocabulary when appropriate.

Full marks will be awarded if the candidate has demonstrated the above abilities.

Questions where Quality of Written Communication is likely to be particularly important are indicated (Quality of Written Communication) in the mark scheme, but this does not preclude others.

## Section A

| Question Number | Answer | Mark |
|-----------------|--------|------|
| 1               | D      | (1)  |

| Question Number | Answer | Mark |
|-----------------|--------|------|
| 2               | B      | (1)  |

| Question Number | Answer | Mark |
|-----------------|--------|------|
| 3               | C      | (1)  |

| Question Number | Answer | Mark |
|-----------------|--------|------|
| 4               | A      | (1)  |

| Question Number | Answer | Mark |
|-----------------|--------|------|
| 5               | C      | (1)  |

| Question Number | Answer | Mark |
|-----------------|--------|------|
| 6               | B      | (1)  |

| Question Number | Answer | Mark |
|-----------------|--------|------|
| 7               | C      | (1)  |

| Question Number | Answer | Mark |
|-----------------|--------|------|
| 8               | A      | (1)  |

| Question Number | Answer | Mark |
|-----------------|--------|------|
| 9               | B      | (1)  |

| Question Number | Answer | Mark |
|-----------------|--------|------|
| 10              | D      | (1)  |

| Question Number | Answer | Mark |
|-----------------|--------|------|
| 11              | D      | (1)  |

| Question Number | Answer | Mark |
|-----------------|--------|------|
| 12              | B      | (1)  |

| Question Number | Answer | Mark |
|-----------------|--------|------|
| 13              | B      | (1)  |

| Question Number | Answer | Mark |
|-----------------|--------|------|
| 14              | C      | (1)  |

| Question Number | Answer | Mark |
|-----------------|--------|------|
| 15              | A      | (1)  |

| Question Number | Answer | Mark |
|-----------------|--------|------|
| 16              | B      | (1)  |

| Question Number | Answer | Mark |
|-----------------|--------|------|
| 17              | D      | (1)  |

| Question Number | Answer | Mark |
|-----------------|--------|------|
| 18              | A      | (1)  |

| Question Number | Answer | Mark |
|-----------------|--------|------|
| 19              | C      | (1)  |

| Question Number | Answer | Mark |
|-----------------|--------|------|
| 20              | C      | (1)  |

**Total for Section A = 20 Marks**

## Section B

| Question Number | Acceptable Answer  | Reject  | Mark |
|-----------------|--|---|------|
| 21(a)(i)        | $\text{Ba(s)} + 2\text{H}_2\text{O(l)} \rightarrow \text{Ba(OH)}_2\text{(aq)} + \text{H}_2\text{(g)}$ <p>OR</p> $\text{Ba(s)} + 2\text{H}_2\text{O(l)} \rightarrow \text{Ba}^{2+}\text{(aq)} + 2\text{OH}^-\text{(aq)} + \text{H}_2\text{(g)}$ <p><b>First mark:</b></p> <p>Correct products.</p> <p><b>Second mark:</b></p> <p>State symbols and balancing.</p> | $\text{Ba}_2$ $\text{H}_2\text{O(aq)}$ $\text{BaO}_2$ | (2)  |

| Question Number | Acceptable Answer   | Reject  | Mark |
|-----------------|---|---|------|
| 21(a)(ii)       | <p><b>First mark:</b></p> <p>Ba(increases in ON) from 0 to +2.</p> <p><b>Second mark:</b></p> <p>H (decreases in ON) from +1 to 0.</p> <p>TE from (a)(i).</p> <p>Stand-alone marks.</p> | Inclusion of oxygen changes will lose 1 mark. | (2)  |

| Question Number | Acceptable Answer  | Mark |
|-----------------|--|------|
| 21(b)           | $\text{Ba(OH)}_2 + 2\text{HCl} \rightarrow \text{BaCl}_2 + 2\text{H}_2\text{O}$ <p>IGNORE state symbols even if incorrect.</p> <p>ALLOW</p> $\text{H}^+ + \text{OH}^- \rightarrow \text{H}_2\text{O}$ <p>TE from (a)(i):</p> $\text{BaO} + 2\text{HCl} \rightarrow \text{BaCl}_2 + \text{H}_2\text{O}$ | (1)  |

| Question Number | Acceptable Answer  | Reject         | Mark |
|-----------------|--|----------------|------|
| 21(c)           | <p><b>White precipitate/white solid/white crystals (rather than colourless solution). (1)</b></p> <p>Barium sulfate is insoluble (whereas barium chloride is soluble). (1)</p> <p>Stand-alone marks.</p> | 'Cloudy' alone | (2)  |

| Question Number | Acceptable Answer   | Reject  | Mark |
|-----------------|---|---|------|
| 21(d)(i)        | <p><b>If flame test is described in (d)(i) then award appropriate marks for (d)(ii).</b></p> <p><b>A correct decomposition equation given in (d)(i) would score 1 mark.</b></p> <p><b>Allow valid discussion of thermal stability appearing in (d)(ii) for mark in (d)(i).</b></p> <p>Barium carbonate is more thermally stable (than magnesium carbonate)/requires more heating/needs a higher temperature/decomposes more slowly/produces carbon dioxide more slowly.</p> <p>OR</p> <p>Reverse argument (MgCO<sub>3</sub> decomposes faster).</p> <p>ALLOW BaCO<sub>3</sub> does not decompose on heating but MgCO<sub>3</sub> does. (1)</p> <p>MCO<sub>3</sub> → MO + CO<sub>2</sub><br/>Where M stands for Mg or Ba. (1)</p> <p>IGNORE state symbols even if incorrect.</p> | <p>Just 'barium'</p> <p>Just 'produces more carbon dioxide'</p> <p>Just 'magnesium'</p> | (2)  |



| Question Number  | Acceptable Answer                                       | Reject                             | Mark       |
|------------------|---|------------------------------------|------------|
| <b>21(d)(ii)</b> | Flame test or description of: Mg does not colour flame. | Magnesium gives white/bright flame | <b>(2)</b> |
|                  | ALLOW colourless/clear. <b>(1)</b>                      |                                    |            |
|                  | Ba: (pale/apple) green flame. <b>(1)</b>                | 'Blue-green'                       |            |
|                  | Stand-alone marks.                                      | Instrument analysis                |            |

**Total for Question 21 = 11 Marks**

| Question Number | Acceptable Answer                     | Reject             | Mark       |
|-----------------|---------------------------------------|--------------------|------------|
| <b>22(a)(i)</b> | Alcohol/ethanol (as solvent for NaOH) | Any other reagents | <b>(1)</b> |
|                 | IGNORE heat/pressure.                 |                    |            |

| Question Number  | Acceptable Answer | Mark       |
|------------------|-------------------|------------|
| <b>22(a)(ii)</b> | Elimination       | <b>(1)</b> |

| Question Number   | Acceptable Answer  | Reject                 | Mark       |
|-------------------|--|------------------------|------------|
| <b>22(a)(iii)</b> | Water (as solvent for NaOH)/aqueous (NaOH)/aqueous (ethanol) | Aqueous silver nitrate | <b>(1)</b> |

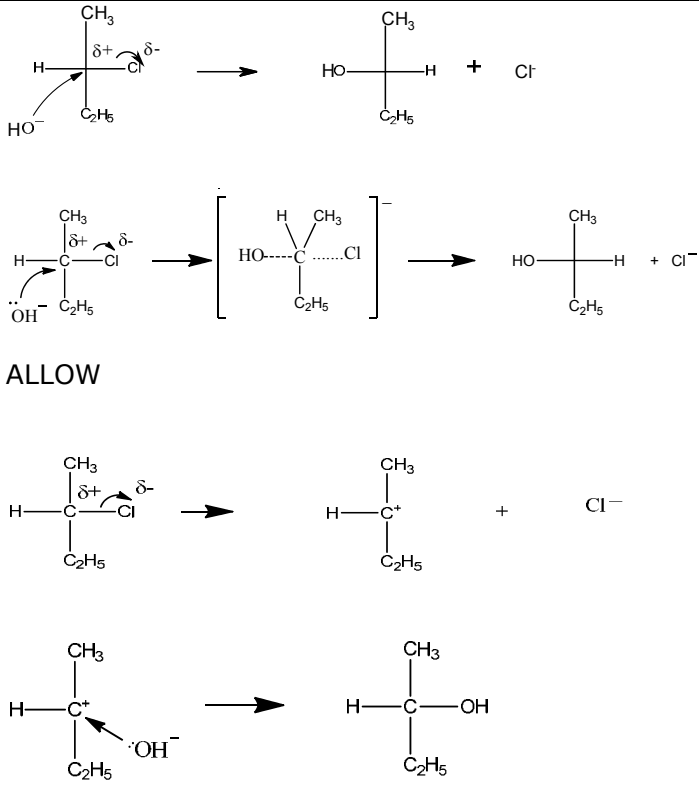
| Question Number                     | Acceptable Answer   | Reject  | Mark              |
|-------------------------------------|---|---|-------------------|
| <p><b>22(a)</b><br/><b>(iv)</b></p> |  <p><b>ALLOW</b></p> <p>Arrow from OH<sup>-</sup> to appropriate C (connected/previously connected) to Cl. <b>(1)</b></p> <p>Arrow from C-Cl bond to Cl producing Cl<sup>-</sup>. <b>(1)</b></p> <p>ACCEPT three dimensional diagrams ; displayed formulae; CH<sub>3</sub>CH<sub>2</sub> for C<sub>2</sub>H<sub>5</sub><br/>Use of C<sub>4</sub>H<sub>9</sub>Cl as formula can score 1 for arrow from C-Cl bond to Cl.</p> <p>Lone pair on hydroxide ion need not be shown.</p> <p>ALLOW solid lines instead of dotted lines in the transition state.</p> | <p>OH without charge</p> <p>Cl (chlorine radical)</p> | <p><b>(2)</b></p> |

| Question Number | Acceptable Answer  | Reject  | Mark       |
|-----------------|--|---|------------|
| <b>22(b)</b>    | Steamy/misty/white <b>and</b> fumes/gas. <b>(1)</b><br>IGNORE fizzing.<br>$\text{CH}_3\text{CH}_2\text{CH}(\text{OH})\text{CH}_3 + \text{PCl}_5 \rightarrow$<br>$\text{CH}_3\text{CH}_2\text{CHClCH}_3 + \text{HCl} + \text{POCl}_3$ <b>(1)</b><br>ALLOW $\text{C}_4\text{H}_9\text{OH}$ and $\text{C}_4\text{H}_9\text{C.l}$<br>ALLOW $\text{PCl}_3\text{O}$ .<br>ACCEPT displayed formulae.<br>ALLOW missing bracket in alcohol.<br>Stand-alone marks. | White smoke<br>Solid<br>$\text{CH}_3\text{CH}_2\text{CH}_2\text{CH}_2$<br>OH<br>$\text{C}_4\text{H}_{10}\text{O}$ | <b>(2)</b> |

| Question Number | Acceptable Answer   | Reject   | Mark       |
|-----------------|---|--|------------|
| <b>22(c)(i)</b> | With butan-2-ol: (change from orange) to green/blue. <b>(1)</b><br>With <b>A</b> : remains orange/no change. <b>(1)</b><br>ALLOW 'no reaction'.<br>Any reference to 'yellow': maximum 1 mark. | Reference to gas given off or formation of precipitate<br>Green-blue<br>Just 'nothing' | <b>(2)</b> |

| Question Number  | Acceptable Answer   | Mark       |
|------------------|---|------------|
| <b>22(c)(ii)</b> | $\text{CH}_3\text{CH}_2\text{COCH}_3$<br>ALLOW displayed or skeletal. | <b>(1)</b> |

| Question Number   | Acceptable Answer  | Reject  | Mark       |
|-------------------|--|---|------------|
| <b>22(c)(iii)</b> | Absorption/peak/trough for O-H/C-O/OH bond/alcohol CO bond would disappear.<br>OR<br>Absorption/peak/trough for C=O/CO ketone bond would appear. | Just OH/CO<br>Just 'alcohol peak'<br>Just 'ketone peak' | <b>(1)</b> |

**Total for Question 22 = 11 Marks**

| Question Number | Acceptable Answer   | Reject  | Mark |
|-----------------|---|---|------|
| 23(a)           | London (forces)/van der Waals' (forces)/temporary dipole-induced dipole (attractions)/dispersion/forces/instantaneous dipole-dipole | Dipole-dipole<br><br>Permanent dipole-dipole<br><br>Just abbreviations, e.g. ID-ID, VdW | (1)  |

| Question Number | Acceptable Answer | Mark |
|-----------------|-------------------|------|
| 23(b)           | 18/eighteen       | (1)  |

| Question Number | Acceptable Answer                                     | Reject   | Mark |
|-----------------|---|--|------|
| 23(c)           | (Permanent) dipole-dipole attractions (also) present. | Hydrogen bonds<br><br>Reference to CH <sub>3</sub> F having more electrons than F <sub>2</sub> | (1)  |

| Question Number | Acceptable Answer  | Mark |
|-----------------|--|------|
| 23(d)           | <b>First mark:</b><br><br>Hydrogen bonds (also) present.<br><br><b>Second mark:</b><br><br>Which are stronger/which require more energy to break than dipole-dipole/London forces/van der Waals' forces/or strongest intermolecular force. | (2)  |

| Question Number | Acceptable Answer  | Reject                                       | Mark |
|-----------------|--|--|------|
| 23(e)           | HCl does not have hydrogen bonds (between molecules)<br><br>IGNORE references to electronegativity | Just 'chlorine does not have hydrogen bonds' | (1)  |

**Total for Question 23 = 6 Marks**

| Question Number | Acceptable Answer   | Mark |
|-----------------|---|------|
| 24(a)(i)        | <p><b>In (a) any units given must be correct. Penalise once only. IGNORE SF except 1SF. Penalise once only. TE throughout.</b></p> <p><math>((0.1 \times 11.6) / (1000)) = 1.16 \times 10^{-3} / 0.00116 / 0.0012 / 1.2 \times 10^{-3} \text{ (mol)}</math></p> | (1)  |

| Question Number | Acceptable Answer  | Reject             | Mark |
|-----------------|--|--------------------|------|
| 24(a)(ii)       | <p><math>(1.16 \times 10^{-3} / 2) = 5.8 \times 10^{-4} / 0.00058 \text{ (mol I}_2 \text{ react with thiosulfate)}</math><br/> <math>6.0 \times 10^{-4} \text{ if } 1.2 \times 10^{-3} \text{ used}</math></p> | $6 \times 10^{-4}$ | (1)  |

| Question Number | Acceptable Answer  | Reject | Mark |
|-----------------|--|--------|------|
| 24(a)(iii)      | <p><math>((50 \times 0.25) / 1000) = 1.25 \times 10^{-2} / 12.5 \times 10^{-3} / 0.0125 \text{ (mol)}</math></p> | 0.012  | (1)  |

| Question Number | Acceptable Answer   | Reject                | Mark |
|-----------------|---|-----------------------|------|
| 24(a)(iv)       | <p>= Answer to (a)(iii) - answer to a(ii)</p> <p><math>(1.25 \times 10^{-2} - 5.8 \times 10^{-4}) = 1.192 \times 10^{-2} / 0.01192 \text{ (mol reacted with tin)}</math></p> <p><math>1.19 \times 10^{-2} / 0.0119 \text{ (mol) if } 6.0 \times 10^{-4} \text{ used}</math></p> <p>ALLOW<br/> <math>1.2 \times 10^{-2} / 0.012 \text{ (mol)}</math></p> | $1.20 \times 10^{-2}$ | (1)  |

| Question Number | Acceptable Answer   | Mark |
|-----------------|---|------|
| 24(a)(v)        | <p>Mass of tin = answer to (a)(iv) <math>\times 118.7 /</math></p> <p style="text-align: right;"><math>= 1.414904 / 1.415 \text{ g} \quad (1)</math></p> <p style="text-align: right;"><math>\% \text{ tin} = \frac{(1.415 \times 100)}{10.25} = 13.803941</math></p> <p style="text-align: right;"><math>= 13.8 \% \quad (1)</math></p> <p>TE from mass if only 1 error in its calculation.</p> <p>13.83/13.8% if <math>1.194 \times 10^{-2}</math> used</p> <p>If answer to (a)(iv) = <math>5.8 \times 10^{-4} \text{ mol I}_2</math> this gives 0.068846 g Sn and 0.67167 % Sn scores. <span style="float: right;">(2)</span></p> <p>Correct answer without working scores. <span style="float: right;">(2)</span></p> <p>ALLOW (1) for 17.5% of SnO<sub>2</sub></p> | (2)  |

| Question Number | Acceptable Answer                                     | Reject                                    | Mark |
|-----------------|---|---|------|
| 24(b)(i)        | Divide solution into separate portions for titration. | Just 'repeat the titration'<br>Use starch | (1)  |

| Question Number | Acceptable Answer  | Reject | Mark |
|-----------------|--|--------|------|
| 24(b)(ii)       | $(0.05 \times 2 \times 100) = (\pm) 0.86\%$<br>11.6<br>ALLOW 0.9%. | 0.90%  | (1)  |

| Question Number | Acceptable Answer   | Reject        | Mark |
|-----------------|---|---------------|------|
| 24(b)(iii)      | Use more dilute thiosulfate (to make titration reading bigger)/Use a larger volume or moles of excess iodine. | Use more rock | (1)  |

| Question Number | Acceptable Answer                           | Reject  | Mark |
|-----------------|---|---|------|
| 24(c)           | (Pale) yellow/straw coloured to colourless. | Clear for colourless<br>Blue/black to colourless<br>Orange/grey/brown | (1)  |

**Total for Question 24 = 10 Marks**

**Total for Section B = 38 Marks**

## Section C

| Question Number | Acceptable Answer   | Mark |
|-----------------|---|------|
| 25(a)(i)        | <p>2.2 g in 1000 g = 2200 g per 1 000 000 g/2200 (ppm)<br/>(greater than 60)</p> <p>OR</p> <p>60ppm = 0.060 (g dm<sup>-3</sup>) (less than 2.2)</p> <p>OR</p> <p>2.2g dm<sup>-3</sup> = 0.22% which is more than 60ppm = 0.006%<br/>(Both values needed as neither is given in question)</p> <p>OR</p> <p>2.2 ÷ 1000 = 2.2 × 10<sup>-3</sup> and 60 ÷ 1000000 = 6 × 10<sup>-5</sup></p> | (1)  |

| Question Number | Acceptable Answer  | Mark |
|-----------------|--|------|
| 25(a)(ii)       | <p>Cl<sub>2</sub> (g/aq) + 2Br<sup>-</sup> (aq) → 2Cl<sup>-</sup> (aq) + Br<sub>2</sub> (aq)</p> <p>Correct species. (1)</p> <p>Balancing and state symbols. (1)</p> | (2)  |

| Question Number | Acceptable Answer   | Reject        | Mark |
|-----------------|---|---------------|------|
| 25(a)(iii)      | (Colourless to) yellow/orange/brown/red-brown colour (or any combination of these colours) appears. | Effervescence | (1)  |

| Question Number | Acceptable Answer   | Mark |
|-----------------|---|------|
| 25(a)(iv)       | <p>Addition of hydrochloric acid increases the concentration of H<sup>+</sup>. (1)</p> <p>Equilibrium shifts to the left/favours the backwards reaction/H<sup>+</sup> combines with Br<sup>-</sup> <b>and</b> BrO<sup>-</sup> to make H<sub>2</sub>O and Br<sub>2</sub> (1)</p> <p>OR</p> <p>The equilibrium will not produce H<sup>+</sup>. (1)</p> <p>So forward reaction will not occur. (1)</p> <p>Stand-alone marks.</p> | (2)  |

| Question Number | Acceptable Answer   | Mark |
|-----------------|---|------|
| 25(a)(v)        | <p><b>First mark:</b></p> <p>The equilibrium shifts to the right/favours the forward reaction.</p> <p><b>Second mark:</b></p> <p>To absorb added heat (energy)/in the endothermic/positive <math>\Delta H</math>.</p> | (2)  |

| Question Number | Acceptable Answer  | Reject  | Mark |
|-----------------|--|---|------|
| 25(a)(vi)       | <p>Greater proportion of/more molecules with energy more than (or equal to) activation energy/sufficient energy to react (at higher temperature).</p> <p>ALLOW particles.</p> <p>ALLOW 'overcome' for 'more than'.</p> | <p>Atoms</p> <p>Lowers activation energy</p> <p>Just 'more successful collisions'</p> | (1)  |

| Question Number | Acceptable Answer  | Mark |
|-----------------|--|------|
| 25(a)(vii)      | <p><b>First mark:</b></p> <p>Bromine (atoms) are (simultaneously) oxidized from 0 to +1 in <math>\text{BrO}^-</math>.</p> <p><b>Second mark:</b></p> <p>And reduced to -1 in <math>\text{Br}^-</math>.</p> | (2)  |

| Question Number | Acceptable Answer   | Reject   | Mark |
|-----------------|---|--|------|
| 25(b)(i)        | <p><b>First mark:</b></p> <p>The forward and backward reactions occur at the same <b>rate</b>.</p> <p><b>Second mark:</b></p> <p>The concentrations or amounts or moles of reactants and products remain constant/intensive or macroscopic properties (e.g. colour) are constant.</p> <p>IGNORE reference to 'closed system'.</p> | <p>Concentrations of products and reactants are the same</p> | (2)  |



| Question Number                                    | Acceptable Answer  | Mark |
|--|--|------|
| *25(b)<br>(ii)<br>Quality of Written Communication | Equilibrium shifts to the right so more CO <sub>2</sub> (g) dissolves/equilibrium shifts to the right so reducing the concentration of CO <sub>2</sub> (aq). (1)<br>So amount of CO <sub>2</sub> in atmosphere/gaseous decreases. (1)<br>Second mark depends on first unless qualified by a near miss. | (2)  |

| Question Number | Acceptable Answer  | Reject                           | Mark |
|-----------------|--|----------------------------------|------|
| 25(b)<br>(iii)  | (Bonds) bend/stretch/vibrate (more)/bonds change polarity or dipole (moment) | Molecules vibrate<br>Bonds break | (1)  |

| Question Number                                   | Acceptable Answer  | Reject                                   | Mark |
|---|--|--|------|
| 25(b)<br>(iv)<br>Quality of Written Communication | <b>First mark:</b><br>Infrared radiation/heat is absorbed by greenhouse gases/by carbon dioxide and water.<br>And one of the following for the <b>second mark:</b><br>When energy from the sun is (re-)emitted from the earth's surface (allow 'reflected').<br>OR<br>IR/heat cannot escape from earth's atmosphere.<br>OR<br>IR/heat is (re-)emitted back to the earth. | IR absorbed from the sun<br>UV radiation | (2)  |

| Question Number                                  | Acceptable Answer  | Reject   | Mark       |
|--|--|--|------------|
| 25(b)<br>(v)<br>Quality of Written Communication | <p><b>First mark:</b></p> <p>Anthropogenic climate change is caused by human activity.</p> <p><b>Second mark:</b></p> <p>Natural climate change is caused by volcanic eruptions etc.</p> <p>Up to any three of the following to a maximum of 4 marks:</p> <p>Water vapour levels always relatively constant/water levels fluctuate normally /water levels vary only to a small extent.</p> <p>CO<sub>2</sub> levels increasing due to (fossil) fuel combustion/deforestation/industrial revolution.</p> <p>CO<sub>2</sub> <b>molecules</b> absorb more IR radiation than H<sub>2</sub>O <b>molecules</b> OR CO<sub>2</sub> <b>molecules</b> have a greater 'greenhouse effect' than H<sub>2</sub>O <b>molecules</b>.</p> <p>Increase in CO<sub>2</sub> levels has accompanied rise in global temperatures.</p> <p>Concern due to melting of ice packs/rising sea levels/flooding/change in sea pH etc.</p> | <p>Reference to UV</p> <p>Reference to ozone depletion negates this mark</p> | <b>(4)</b> |

**Total for Question 25 = 22 marks**

**Total for Section C = 22 Marks**

**Total for Paper = 80 marks**